

Technical Bulletin # 659H

Product Description

CHOCKFAST ORANGE (PR-610TCF) is a specially formulated 100% solids, two component inert filled casting compound developed for use as a chocking or grouting material. CHOCKFAST is designed to withstand severe marine and industrial environments involving a high degree of both physical and thermal shock. The compound is non-shrinking and has very high impact and compressive strength.

Years of successful in-service experience have shown the use of PR-610TCF to be a far superior yet less expensive method of establishing and permanently retaining precise equipment alignment under extreme conditions.

PR-610TCF is approved or accepted for its intended marine use by American Bureau of Shipping, Lloyd's Register, Bureau Veritas, Det Norske Veritas, Germanischer Lloyd and most other major regulatory agencies worldwide.

Use & Benefits

CHOCKFAST ORANGE was developed as a chocking or grouting compound for use under marine main propulsion machinery in depths of ½" to 4" (12mm to 100mm). The compound is used under diesel and gas engines, reduction gears, generators, compressors, pumps, bearing blocks, crane rails and numerous other applications.

PR-610TCF requires no special tools or special skills as does chocking with steel. When cast, CHOCKFAST ORANGE flows readily into the chock area filling voids and conforming to all irregularities. This eliminates the machining of base plates or foundations for a perfectly fitted chock.

Design Considerations

For design considerations and application details please request Bulletin No. 692 for Marine and 642 for Industrial applications or contact ITW Philadelphia Resins' Engineering Services Department.

Application Instructions

Using open-cell foam damming material, build a dam around 3 sides of the area to be chocked. Wrap the anchor bolt with tape so the Chockfast will not stick to it. Install a metal dam along the front of the chock approximately ½" to ¾" (12mm to 18mm) from the mounting flange. Seal the flange with strip caulking, or Silicone to prevent leaks. Install foam in the overpour area to the top of the mounting flange to prevent the Chockfast from leaking.

Mix the Chockfast as directed on the can. See technical Bulletin #665 to determine the proper amount of hardener to use. Slowly pour the Chockfast into one end of the overpour area and allow it to flow across and under the mounting flange.

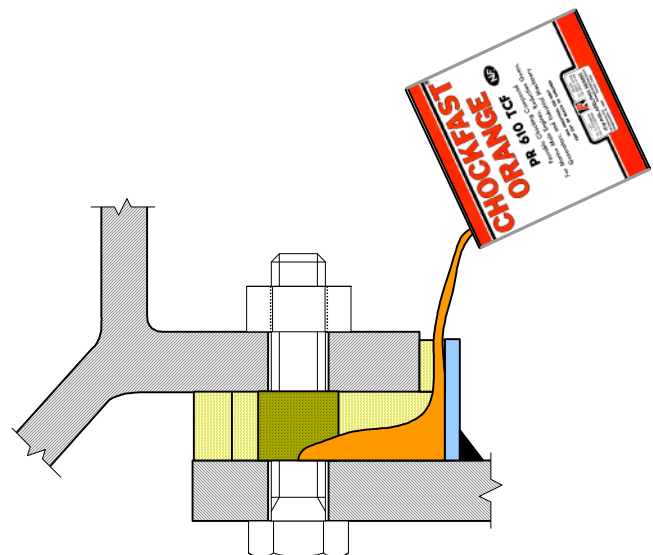

ITW POLYMER TECHNOLOGIES

130 Commerce Drive • Montgomeryville, PA 18936 • 215-855-8450 • Fax 215-855-4688

ITW Philadelphia Resins
Registered to ISO 9001:2000
File No. A3790

ISO 9001:2000

CERTIFIED

ITW Performance Polymers Europe
ISO 9001:2000
Q85-02

Physical Properties

COMPRESSIVE STRENGTH	19,000 psi (1,336 kg/cm ²)	ASTM D-695MOD
COMPRESSIVE MODULUS OF ELASTICITY	533,000 psi (37,482 kg/cm ²)	ASTM D-695
LINEAR SHRINKAGE	0.0002 in/in (0.0002 mm/mm) or 0.02%	ASTM D-2566
COEFFICIENT OF LINEAR THERMAL EXPANSION	17.1 x 10 ⁻⁶ /F° @ 32°F to 140°F (30.8 x 10 ⁻⁶ /C° @ 0°C to 60°C)	ASTM D-696
FLEXURAL STRENGTH	7,615 psi (575 kg/cm ²)	ASTM C-580
FLEXURAL MODULUS OF ELASTICITY	8.6 x 10 ⁵ psi (72,880 kg/cm ²)	ASTM C-580
TENSILE STRENGTH	4,970 psi (349 kg/cm ²)	ASTM D-638
SHEAR STRENGTH	5,400 psi (380 kg/cm ²)	FED-STD-406 (Method 1041)
IZOD IMPACT STRENGTH	6 in.lbs/in. (0.27 N.m/cm)	ASTM D-256
SHOCK RESISTANCE	Pass MIL-S-901C (Navy) High Impact Shock Test, Grade A, Type A, Class 1	
THERMAL SHOCK	Pass -0°F to 212°F (18°C to 100°C)	ASTM D-746
VIBRATION	Meets MIL-STD-167	
FIRE RESISTANCE	Self extinguishing	ASTM D-635
SPECIFIC GRAVITY	1.58	
BARCOL HARDNESS	40+ fully cured - 35 minimum	ASTM D-2583

Product Information

UNIT COVERAGE	Small Unit: 120 cu.in (1,966 cc) Large Unit: 260 cu.in (4,261 cc)
APPLICATION TEMPERATURE	55°F (13°C) to 95°F (35°C)
PACKAGING per Unit	<u>Small Unit:</u> Resin (NH) - 7.2 lbs. (3.3 kg), 0.53 gal (2 L) in a 1 gal can, Hardener (H) -0.5 lbs. (0.23 kg), 7.9 oz (0.23 L) in an 8 oz plastic bottle <u>Large Unit:</u> Resin (NH) - 14.4 lbs. (6.5 kg), 1.052 gal (3.98 L) in a 2 gal pail, Hardener (H) -0.99 lbs. (0.45 kg), 15.49 oz (0.458 L) in an 16 oz plastic bottle
UNIT SHIPPING WEIGHT	Small Unit: 9 lbs (4 kg) Large Unit: 17 lbs. (7.7 kg)
CURE TIME (approximate)	48 hours @ 60°F (15°C) 24 hours @ 70°F (21°C) 36 hours @ 65°F (18°C) 18 hours @ 80°F (26°C)
POT LIFE	30 min. @ 70°F (21°C)
SHELF LIFE	2 years
CLEAN UP	IMPAX IXT-59 or similar epoxy solvent

Reference

For design considerations and application details please request Bulletin No. 692, 642 or contact ITW Philadelphia Resins' Engineering Services Department.

Date

03/2010

General: Every reasonable effort is made to insure the technical information and recommendations on these data pages are true and accurate to the best of our knowledge at the date of issuance. However, this information is subject to change without notice. Prior versions of this publication are invalid with the release of this version. Products and information are intended for use by qualified applicators that have the required background, technical knowledge, and equipment to perform said tasks in a satisfactory manner. Consult your local distributor for product availability, additional product information, and technical support.
Warranty: ITW Polymer Technologies, a division of Illinois Tool Works Inc., warrants that its products meet their printed specifications. This is the sole warranty. This warranty expires one year after product shipment.
Warranty Claims: If any product fails to meet the above, ITW Polymer Technologies will, at its option, either replace the product or refund the purchase price. ITW Polymer Technologies will have no other liability for breach of warranty, negligence, or otherwise. All warranty claims must be made in writing within one year of the date of shipment. No other claims will be considered.
Disclaimer: ITW Polymer Technologies makes no other warranty, expressed or implied, and specifically disclaims any warranty of merchantability or fitness for a particular purpose.

Suggestions concerning the use of products are not warranties. The purchaser assumes the responsibility for determining suitability of products and appropriate use. ITW Polymer Technologies' sole liability, for breach of warranty, negligence or otherwise, shall be the replacement of product or refund of the purchase price, ITW Polymer Technologies' election. Under no circumstances shall ITW Polymer Technologies be liable for any indirect, incidental or consequential damages.
Modification of Warranty: No distributor or sales representative has the authority to change the above provisions. No change in the above provisions will be valid unless in writing and signed by an officer or the Technical Director of ITW Polymer Technologies. No term of any purchase order shall serve to modify any provision of this document.
Mediation and Arbitration: If any dispute arises relating to products or product warranties, either the purchaser or ITW Polymer Technologies may a) initiate mediation under the then current Center for Public Resources (CPR) Model Procedure for Mediation of Business Disputes, or b) initiate a non-binding arbitration under the rules of the American Arbitration Association for the resolution of commercial disputes.